Intermot Hydraulic Motors

IHM Series

H2 Models

IHM 175 – 200 – 220 – 250 – 300 – 350 – 400 H2

INDEX

TECHNICAL DATA	Pag. 13
IHM 175 – 200 – 220 – 250	
300 – 350 – 400 H2	Pag. 14
ORDERING INSTRUCTIONS	Pag. 15

IHM H2

Technical data

MODEL		N° of pistons	Displacement	Pressure		Speed		Torque		Dry Mass
				Max Cont.	Peak	Minimum speed	Max speed	Rated	Specific	
			cm3/rev	bar		rpm		Nm	Nm/MPa	
IHM H2	175	5	181	250	320	8	1000	670	27	35
	200		201	250	320	8	800	743	30	
	220		222	250	320	8	800	819	33	
	250		254	200	250	8	630	752	38	
	300		289	200	250	8	500	856	43	
	350		340	200	250	8	400	1000	50	
	400		380	180	225	8	350	1008	56	

IHM H2

Dimensional drawings

IHM 175 – 200 – 220 – 250 – 300 – 350 – 400 H2

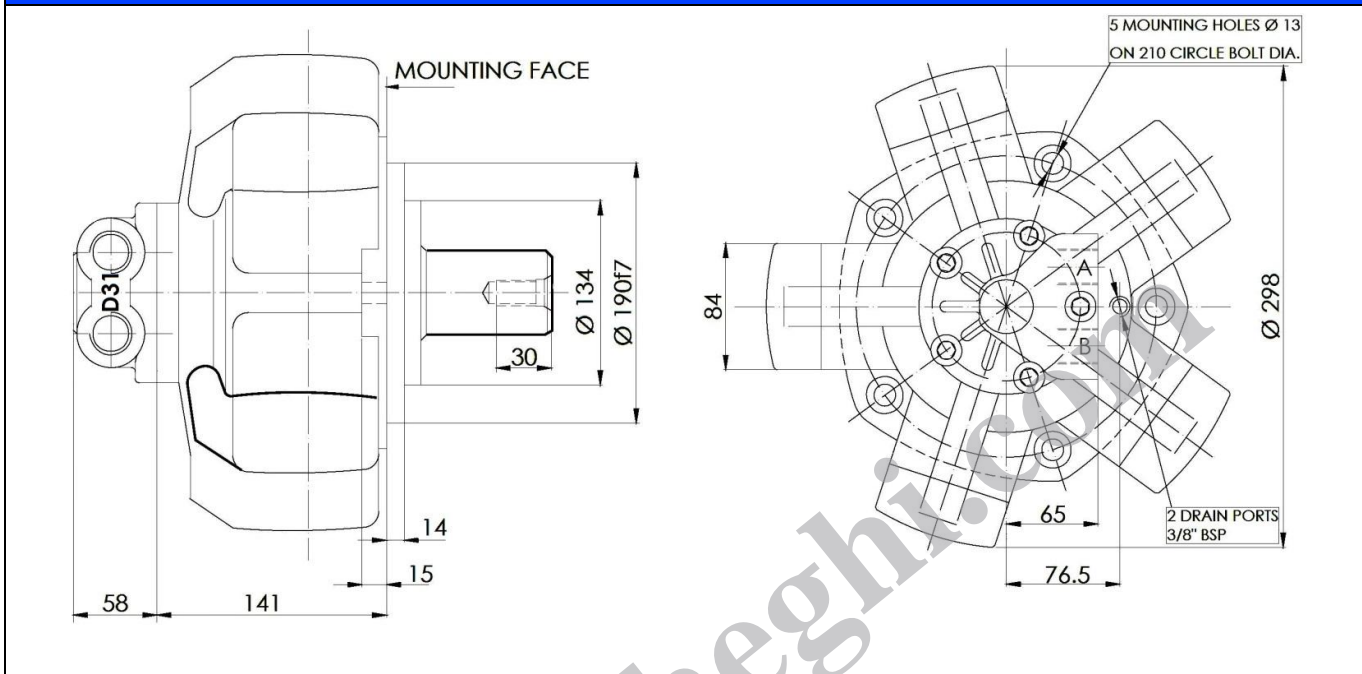

SHAFTS

A0: Standard Splined Shaft	A2: Parallel Shaft on Request	A3: Internal Splined Shaft

For further shaft configurations, please contact our technical department

